

Ophthalmic instruments — Tonometers (ISO 8612:2009)

ICS 11.040.70

National foreword

This British Standard is the UK implementation of EN ISO 8612:2009. It supersedes BS EN ISO 8612:2001 which is withdrawn.

The UK participation in its preparation was entrusted to Technical Committee CH/172/6, Ophthalmic instruments.

A list of organizations represented on this committee can be obtained on request to its secretary.

This publication does not purport to include all the necessary provisions of a contract. Users are responsible for its correct application.

Compliance with a British Standard cannot confer immunity from legal obligations.

This British Standard was published under the authority of the Standards Policy and Strategy Committee on 30 November 2009.

© BSI 2009

ISBN 978 0 580 60809 4

Amendments/corrigenda issued since publication

Date	Comments

English Version

Ophthalmic instruments - Tonometers (ISO 8612:2009)

Instruments ophtalmiques - Tonomètres (ISO 8612:2009)

Ophthalmische Instrumente - Augentonometer (ISO 8612:2009)

This European Standard was approved by CEN on 10 September 2009.

CEN members are bound to comply with the CEN/GENELEC Internal Regulations which stipulate the conditions for giving this European Standard the status of a national standard without any alteration. Up-to-date lists and bibliographical references concerning such national standards may be obtained on application to the CEN Management Centre or to any CEN member.

This European Standard exists in three official versions (English, French, German). A version in any other language made by translation under the responsibility of a CEN member into its own language and notified to the CEN Management Centre has the same status as the official versions.

CEN members are the national standards bodies of Austria, Belgium, Bulgaria, Cyprus, Czech Republic, Denmark, Estonia, Finland, France, Germany, Greece, Hungary, Iceland, Ireland, Italy, Latvia, Lithuania, Luxembourg, Malta, Netherlands, Norway, Poland, Portugal, Romania, Slovakia, Slovenia, Spain, Sweden, Switzerland and United Kingdom.



EUROPEAN COMMITTEE FOR STANDARDIZATION
COMITÉ EUROPÉEN DE NORMALISATION
EUROPÄISCHES KOMITEE FÜR NORMUNG

Management Centre: Avenue Marnix 17, B-1000 Brussels

Foreword

This document (EN ISO 8612:2009) has been prepared by Technical Committee ISO/TC 172 "Optics and photonics" in collaboration with Technical Committee CEN/TC 170 "Ophthalmic optics" the secretariat of which is held by DIN.

This European Standard shall be given the status of a national standard, either by publication of an identical text or by endorsement, at the latest by April 2010, and conflicting national standards shall be withdrawn at the latest by April 2010.

Attention is drawn to the possibility that some of the elements of this document may be the subject of patent rights. CEN [and/or CENELEC] shall not be held responsible for identifying any or all such patent rights.

This document supersedes EN ISO 8612:2001.

According to the CEN/CENELEC Internal Regulations, the national standards organizations of the following countries are bound to implement this European Standard: Austria, Belgium, Bulgaria, Cyprus, Czech Republic, Denmark, Estonia, Finland, France, Germany, Greece, Hungary, Iceland, Ireland, Italy, Latvia, Lithuania, Luxembourg, Malta, Netherlands, Norway, Poland, Portugal, Romania, Slovakia, Slovenia, Spain, Sweden, Switzerland and the United Kingdom.

Endorsement notice

The text of ISO 8612:2009 has been approved by CEN as a EN ISO 8612:2009 without any modification.

Contents

Page

Foreword	iv
1 Scope	1
2 Normative references	1
3 Terms and definitions	1
4 Requirements	2
4.1 General	2
4.2 Design compliance testing (certification)	2
4.3 Verification (instrument compliance)	2
4.4 Construction and function	3
5 Test methods	3
6 Accompanying documents	3
7 Additional information	3
8 Marking	4
Annex A (normative) Reference tonometer and method for determining reference IOP	5
Annex B (normative) Design compliance testing	12

Foreword

ISO (the International Organization for Standardization) is a worldwide federation of national standards bodies (ISO member bodies). The work of preparing International Standards is normally carried out through ISO technical committees. Each member body interested in a subject for which a technical committee has been established has the right to be represented on that committee. International organizations, governmental and non-governmental, in liaison with ISO, also take part in the work. ISO collaborates closely with the International Electrotechnical Commission (IEC) on all matters of electrotechnical standardization.

International Standards are drafted in accordance with the rules given in the ISO/IEC Directives, Part 2.

The main task of technical committees is to prepare International Standards. Draft International Standards adopted by the technical committees are circulated to the member bodies for voting. Publication as an International Standard requires approval by at least 75 % of the member bodies casting a vote.

Attention is drawn to the possibility that some of the elements of this document may be the subject of patent rights. ISO shall not be held responsible for identifying any or all such patent rights.

ISO 8612 was prepared by Technical Committee ISO/TC 172, *Optics and photonics*, Subcommittee SC 7, *Ophthalmic optics and instruments*.

This second edition cancels and replaces the first edition (ISO 8612:2001), which has been technically revised.

Ophthalmic instruments — Tonometers

1 Scope

This International Standard, together with ISO 15004-1, specifies minimum requirements and the design compliance procedure for tonometers intended for routine clinical use in the estimation of intraocular pressure (IOP).

This International Standard takes precedence over ISO 15004-1, if differences exist.

NOTE The true intraocular pressure is seldom directly measured since it would require invasion of the eye. Since the true IOP cannot be clinically measured, alternative methods are specified for determining a reference IOP (Annex A and Annex B).

2 Normative references

The following referenced documents are indispensable for the application of this document. For dated references, only the edition cited applies. For undated references, the latest edition of the referenced document (including any amendments) applies.

ISO 15004-1, *Ophthalmic instruments — Fundamental requirements and test methods — Part 1: General requirements applicable to all ophthalmic instruments*

IEC 60601-1:2005, *Medical electrical equipment — Part 1: General requirements for basic safety and essential performance*

3 Terms and definitions

For the purposes of this document, the following terms and definitions apply.

3.1

intraocular pressure

IOP

pressure within the eye

NOTE It is expressed in millimetres of mercury (mmHg), where 1 mmHg = 0,133 3 kPa.

3.2

reference tonometer

tonometer as described in Annex A

3.3

test tonometer

verified tonometer used in design compliance testing

3.4

reference IOP

IOP that is measured with a reference tonometer, as specified in Annex A, in accordance with the procedures given in Annex B

3.5 measured IOP

IOP reading provided by the test tonometer when used in accordance with the manufacturer's instructions

4 Requirements

4.1 General

4.1.1 The test tonometer shall conform to the general requirements specified in ISO 15004-1.

4.1.2 The test tonometer shall conform to the specific requirements specified in 4.2 to 4.4.

4.2 Design compliance testing (certification)

4.2.1 The manufacturer shall demonstrate, on the basis of design compliance testing as specified in Clause 5, that the test tonometer measurements, when compared to the reference tonometer measurements, meet the requirements as given in Table 1.

A tonometer that meets the requirements of Annex A for a reference tonometer need not undergo design compliance testing.

The requirements are met if not more than 5 % of the paired differences between the reference tonometer reading and the test tonometer reading for each pressure range are greater than the tolerance for that range in Table 1.

NOTE The tolerances given in Table 1 represent 1,96 times the standard deviation allowable for the paired measurement, and so account for not only the allowable error of the tonometer under test but also unavoidable error associated with the reference tonometer.

Table 1 — Requirements for tonometers

IOP range mmHg	Tolerance mmHg	Minimum number of eyes
7 to 16	±5,0	40
> 16 to < 23	±5,0	40
≥ 23	±5,0	40

4.2.2 The manufacturer shall analyse the data, taken in the course of design compliance testing as specified in Clause 5, using the total least squares method for the regression, and make available, as required in Clause 7, the slope, the offset and the standard deviation of the regression line.

4.3 Verification (instrument compliance)

4.3.1 The manufacturer shall develop a method and test apparatus to confirm that the design requirements of 4.2 are met by each manufactured tonometer. Each tonometer shall be verified with this method and apparatus. This method and test apparatus shall be the same as those used to measure and verify the test tonometer in 4.2.

4.3.2 The permissible error of the test apparatus shall be less than or equal to one-half of the permissible tolerance as given in Table 1.

4.4 Construction and function

4.4.1 The surfaces of the tonometer that are intended to come into contact with the cornea shall be:

- a) composed of non-toxic, stable and non-oxidative material which is inert to ocular tissue, tears and appropriate pharmacological agents;
- b) designed either to facilitate disinfection or for single patient use;
- c) free of surface irregularities and imperfections when viewed with unmagnified corrected vision.

4.4.2 The tonometer shall permit the measurement of IOP throughout the range 7 mmHg to 50 mmHg. The scale or display shall either provide a direct measurement of a value whose relationship to IOP is known or give a numerical reading corresponding to the IOP value.

Readings of IOP less than 7 shall be displayed either by their numerical value or by a "low reading" indication. Readings of IOP greater than 50 shall be displayed either by their numerical value or by a "high reading" indication.

5 Test methods

5.1 This International Standard describes type testing (certification) and individual device testing (verification).

5.2 The reference IOP shall be determined as described in Annex A.

5.3 Design compliance testing shall be performed as described in Annex B.

6 Accompanying documents

The tonometer shall be accompanied by documents containing instructions for use together with maintenance procedures and their frequency of application. In particular, this information shall contain:

- a) name and address of the manufacturer;
- b) instructions for effective disinfection of the tonometer where applicable;
- c) contra-indications for the use of the tonometer;
- d) a list of accessories suitable for use with the tonometer;
- e) if appropriate, any additional documents as specified in 7.9 of IEC 60601-1:2005;
- f) a reference to this International Standard, i.e. ISO 8612:2009, if the manufacturer or supplier claims compliance with it.

7 Additional information

Upon request, the manufacturer shall provide information on the operating principles of the certified tonometer.

8 Marking

The tonometer shall be permanently marked with at least the following information:

- a) name of manufacturer or supplier;
- b) name and model of tonometer;
- c) if applicable, marking as required by IEC 60601-1.

Annex A (normative)

Reference tonometer and method for determining reference IOP

A.1 Specifications of the reference applanation tonometer

A.1.1 General

The reference tonometer shall be a mechanical-optical applanation tonometer that measures the force required to produce a given area of applanation.

A.1.2 Area of applanation

The area of applanation shall be circular with a diameter of 3,06 mm. The manufacturing tolerance for the diameter of the applanation circle shall be $\pm 0,02$ mm.

A.1.3 Surface of tonometer head

The front (contact) surface of the tonometer head shall have a diameter of at least 6,0 mm and shall be smooth to the touch. When examined by unmagnified corrected vision under direct illumination, the surface shall be free from surface imperfections (free from fissures, cracks and dents) that could damage the eye. Over a central area of not less than 4 mm diameter, the front surface shall be a plane structure with a "peak to valley" deviation from a plane surface of less than 3,0 μm . The outer edge of this tonometer head shall be smoothed. The front surface flatness requirement shall be verified using the method given in A.2.3.6 or an alternate equivalent method.

A.1.4 Measuring force

The measuring force shall be continuously adjustable within a minimum range extending from 0 mN to 49,0 mN, without the use of auxiliary weights. The measured value of the force shall be clearly legible on a linearly divided scale or a digital indication.

The change of force required to move the tonometer head in the opposite direction (reverse span) at the point of transition shall not exceed 0,49 mN.

A.1.5 Display

If lines are used as graduations on the measuring scale, they shall be straight, of equal width, and shall be engraved or otherwise permanently marked. No line shall be wider than 1/4 of the distance between two lines.

If a digital display is used, the increments shall be ≤ 1 mmHg.

One scale unit shall represent either 0,98 mN or 1,96 mN. The main scale graduations shall be numbered with a value. The width of the reference mark shall be no greater than the smallest width of the graduation lines on the measuring scale.

A.1.6 Tolerance for measurement of force

When the tonometer head is adjusted to the verification position, the tolerance for the measured value of the force within the measuring range shall be $\pm 1,5$ % of the nominal value or $\pm 0,49$ mN, whichever is greater, over a temperature range from 15 °C to 30 °C.

A.2 Verification of reference tonometer

A.2.1 General

The reference tonometer shall be verified using the apparatus given in A.2.2 or an alternative equivalent method.

A.2.2 Apparatus

A.2.2.1 Optical limit gauge, consisting of a left line and two right vertical lines divided horizontally by a dashed line, for testing the applanation circle diameter (see Figure A.1). The distance between the right lines corresponds to twice the value of the tolerances of the applanation circle diameter specified in A.1.2.

Dimensions in millimetres

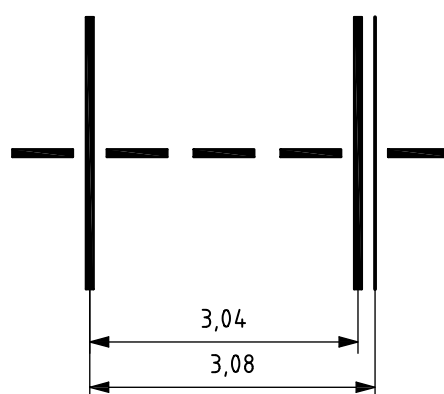

Figure A.1 — Optical limit gauge for verifying diameter of the applanation circle of 3,06 mm

A.2.2.2 Balance, of 0,01 g/scale division sensitivity for a) testing the measuring force, b) testing the reverse span for transitional movement of the tonometer head into the opposite direction, and c) for checking the position of the measuring arm with reference to its freedom of movement at equilibrium of forces.

A.2.2.3 Flatness tester, comprising a low pressure sodium lamp, a glass optical flat (flatness tolerance of $< 1/8$ wave at 589 nm) and a 10 \times magnifier lens for determining the flatness of the central 4 mm of the reference tonometer head (see Figure A.2).

A.2.3 Verification procedures

A.2.3.1 General

The reference tonometer shall be verified using the method given below or an equivalent method.

A.2.3.2 Diameter of the applanation circle

Substitute the optical limit gauge (A.2.2.1) for the examined eye. Orient the dividing line of the prisms so that it coincides with the dashed line. The action of the doubling prisms is to displace the images of the lines above and below the dividing line by a combined distance equal to the applanation circle diameter, so that they appear to come into coincidence (see Figure A.3). For a tonometer head without doubling prisms, determine the applanation circle diameter using a lined square that is verified by direct comparison with the optical gauge.

The tonometer shall comply with the tolerance requirements if the transposed lower half-line lies within the lateral interval delineated by the upper right line pair (Figure A.3).

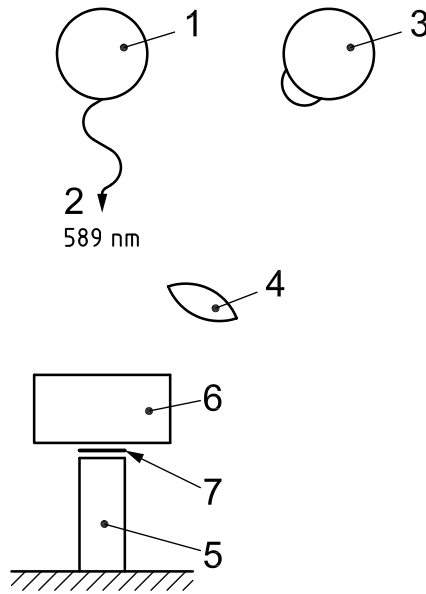

Key

- 1 low pressure sodium lamp, e.g. SOX18 (ANSI L69)
- 2 radiation of wavelength 589 nm
- 3 observer
- 4 magnifier, 10×
- 5 tonometer tip under test
- 6 glass optical flat, 1/8 wave
- 7 interference fringes

Figure A.2 — Optical apparatus for verifying 3 μm flatness of the reference tonometer head

Dimensions in millimetres

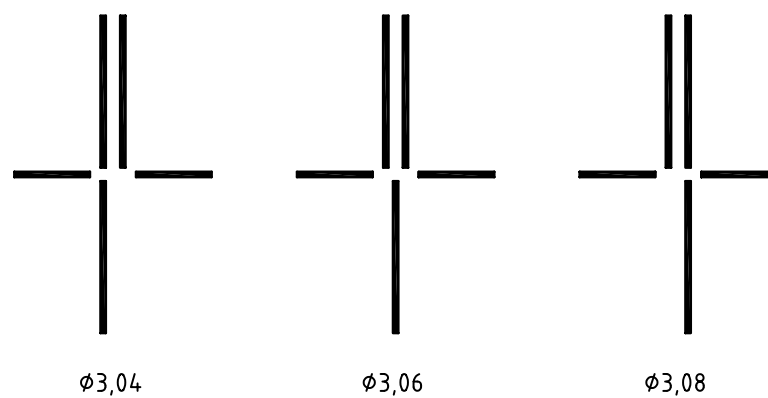

Figure A.3 — Verification of tolerance limits for diameter of the applanation circle, here for diameter values of 3,04 mm, 3,06 mm and 3,08 mm

A.2.3.3 Measuring force, reverse span and central position of the tonometer arm

The measuring force, reverse span and central position of the tonometer are verified by using the tonometer balance system (see Figure A.4) as follows.

NOTE Numbers in parentheses in the following instructions refer to Figure A.4.

Attach the applanation tonometer to the balance system by means of a holding device. Align one of the contact wheels to the tonometer head (1) using a three-coordinate fine adjustment, so that the contact wheel touches the centre of the tonometer head applanation surface and presses against it with enough force such that the balance pointer (3) is aligned to the zero index mark. The tonometer pressure setting for this step shall be in the centre of the measuring range, midway between the front and back overloading stops. Check the balance system for freedom of movement by loading the balance with a 0,5 g weight (2) and ensuring that the pointer swings to the lower balance stop. After ensuring freedom of movement of the balance system, remove the 0,5 g weight. Next, ensure that the balance system responds freely to changes in the tonometer pressure setting as follows:

- adjust the applanation tonometer to a value that corresponds to an IOP of 10 mmHg;
- symmetrically align the tonometer head with the contact wheel without touching it;
- move the tonometer head towards the contact wheel until the balance swings clearly over its zero point;
- adjust the applanation tonometer to a value that corresponds to an IOP of 0 mmHg;
- successively place weights in increments of 1 g on the balance, from 1 g up to the maximum load. Increase the measuring force of the tonometer as the weights are added to the balance, until the pointer again coincides with the zero index mark;
- carry out the test starting with the maximum weight and decreasing the tonometer measuring force;
- adjustment and checking of the applanation tonometer shall be carried out using a low-vibration device.

The tonometer shall comply with the requirements specified in A.1.4 and A.1.6 if the deviations of the various values of the measuring force from nominal values, as displayed by the tonometer scale, do not exceed the tolerance values, and if the change of force required to move the tonometer head in the reverse direction (reverse span) does not exceed the value specified in A.1.4.

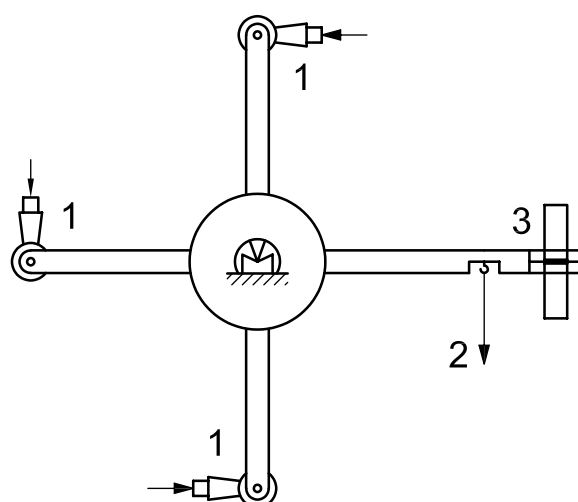

Key

- 1 contact wheels and pressure bodies at the different measuring positions
- 2 balance weight
- 3 pointer and zero index

Figure A.4 — Arrangement for verifying the measuring force

A.2.3.4 Width of lines on the measuring drum

The tonometer shall comply with the requirements specified in A.1.5, if the measured width is less than or equal to the width of the standard line.

A.2.3.5 Variation of measuring-force scale reading between 15 °C and 30 °C

The test should, in general, be carried out only once for each reference tonometer.

Place the tonometer, mounted on the tonometer balance, in a room in which the temperature can be adjusted.

Monitor the scale readings as a function of temperature.

The tonometer shall comply with the requirements specified in A.1.6 if, throughout the temperature range, the scale readings do not vary by more than the permitted limits.

A.2.3.6 Flatness over central 4 mm diameter of tonometer head

Clean the front and back surfaces of the tonometer head per manufacturer's instructions. The optical flat and the tonometer as shown in Figure A.2 shall be free of any dust or dirt that would affect the contact between the flat and the tonometer head. Place the tonometer head on a clean surface and place the optical flat on top of the tip under the sodium lamp illumination. Allow the sodium lamp to warm up for at least 5 min. Using a lens of not less than 10× magnification observe the fringe pattern appearing at the optical flat-tonometer head tip interface. There shall be ten or less fringes at the interface over the 4 mm central diameter.

A.2.4 Test certificate

The results of verification testing, carried out in accordance with this International Standard, shall be recorded in a test certificate provided by the manufacturer in the countries where no legal verification is available. An example of a test certificate is illustrated in Figure A.5.

A.3 Protocol for using the reference tonometer

The following procedure shall be carried out when using the reference tonometer in the design compliance testing specified in Annex B.

- a) Anaesthetize the selected eye of the subject.
- b) Stain with sodium fluorescein.

NOTE Steps a) and b) can be combined by using an anaesthetic to which sodium fluorescein has already been added.

- c) Set the tonometer drum to a force corresponding to an IOP of 10 mmHg.

If possible, do not touch the eyelid with the fingers in order to open the palpebral aperture. If the palpebral aperture is not wide enough to allow the tonometer cone to make contact, instruct the subject to open his/her eyes wider.

- d) Direct the subject to view a distance fixation point. If distance fixation cannot be maintained and near fixation is used, this fact should be recorded.
- e) Measure the intraocular pressure for the mean of the ocular pulse and remove the tonometer from the eye.

- f) Repeat steps c), d) and e) if the measurement was not valid because:
 - 1) the patient felt a sensation;
 - 2) the eyelid was touched;
 - 3) the fluorescein ring was too broad or too thin;
 - 4) any other circumstances suggest that the measurement may have been inaccurate.
- g) If there is any evidence that the anaesthetic is no longer fully effective, re-administer the anaesthetic.
- h) Repeat steps c), d), e) and f) if a series of multiple measurements is suggested. After the first measurement for a given subject has been taken, all valid subsequent measurements shall be recorded when a series of multiple measurements are desired. If any interruption to the consecutive readings occurs, then recommence the procedure.

Tonometer Test Certificate

Tonometer No.: _____ Date: _____

Sender: _____ Tester: _____

Manufacturer: _____ Controller: _____

Diameter of applanation circle, nominal 3,06 mm or _____ ±0,02 mm

a) Tonometer head No. 1 _____ mm b) Tonometer head No. 2 _____ mm

MEASURING FORCE

Initial state: The tonometer arm shall be adjusted symmetrically in the free space available for movement with reference to the verification position.

Nominal requirement	Error	
	Horizontal	Vertical
9,81 ± 0,49 mN	_____ mN	_____ mN
19,61 ± 0,49 mN	_____ mN	_____ mN
29,42 ± 0,49 mN	_____ mN	_____ mN
39,23 ± 0,59 mN	_____ mN	_____ mN
49,03 ± 0,74 mN	_____ mN	_____ mN
58,84 ± 0,88 mN	_____ mN	_____ mN
68,65 ± 1,03 mN	_____ mN	_____ mN
78,45 ± 1,18 mN	_____ mN	_____ mN

Reverse span at the transition of tonometer head movement into the opposite direction:

0,49 mN maximum _____ mN

Position of measuring arm relative to its free play at equilibrium of force:

Middle _____

Tip flatness (10 fringes maximum) _____ fringes

Remarks: _____

Result: _____ Verified _____ Not verified

Signature: _____

Figure A.5 — Example of a test certificate

Bought by- Peter Frampton, Company - Aaron Optometrists, on 22 March 2015. Latest version. Not to be distributed/networked. For multi-user access www.bsigroup.com/license © The British Standards Institution 2015.

Annex B (normative)

Design compliance testing

B.1 General

The sponsor of the test shall appoint a monitor to take overall responsibility for the conduct of the test. The monitor shall have no vested or commercial interest in the test tonometer or the outcome of the test.

B.2 Investigators

B.2.1 The monitor shall recruit a minimum of two investigators per centre who will be responsible for the measurements of the IOPs using both the reference tonometer and test tonometer.

B.2.2 The persons conducting the design compliance testing shall have no vested or commercial interest in the test tonometer or the outcome of the test.

NOTE The test can be multi-centred.

B.3 Training

B.3.1 The monitor shall ensure that all investigators are fully trained in the use of both the reference and test tonometers. The investigators shall be made aware that they shall follow the protocol and manufacturer's instructions exactly and at all times.

B.3.2 During the test, the investigators shall not be given any further instruction on the use of the tonometers, nor shall they be given any feedback on the results of the measurements.

B.4 Tonometers

B.4.1 Compliance with the specifications of the test tonometer(s) shall be verified using the methods and apparatus described in 4.3.

B.4.2 The monitor shall ensure that calibration of the reference tonometer is verified at least at the beginning and end of the test.

B.4.3 The test tonometer(s) shall not be subject to non-routine adjustment of the calibration.

B.5 Subjects

B.5.1 Subjects shall be selected according to the following exclusion criteria:

- a) subjects with only one functional eye;
- b) those with one eye having poor or eccentric fixation;
- c) high corneal astigmatism (i.e. those eyes displaying an oval contact image with the Goldmann tonometer);

- d) subjects with corneal scarring or who have had corneal surgery, including corneal laser surgery;
- e) microphthalmos;
- f) buphthalmos;
- g) contact lens wearers;
- h) dry eyes;
- i) lid squeezers (blepharospasm);
- j) nystagmus;
- k) keratoconus;
- l) any other corneal or conjunctival pathology or infection;
- m) central corneal thickness greater than 0,600 mm or less than 0,500 mm (2 standard deviations about the human mean).

B.5.2 The monitor shall specify other exclusion criteria that the investigators are to adopt, but only if these affect the conditions under which the test tonometer is claimed to operate.

B.5.3 The minimum number of measurement pairs in the test shall be 120. There shall not be less than the following numbers of measurement pairs in each of the pressure groups (as determined by the reference tonometer).

7 mmHg to 16 mmHg	40 measurement pairs
> 16 mmHg to < 23 mmHg	40 measurement pairs
≥ 23 mmHg	40 measurement pairs

In the ≥ 23 mmHg group, repeat measurement pairs may be acquired from the same eye. In this group the maximum number of measurement pairs per eye acquired in this manner shall be six. Of the 40 measurement pairs in this group at least two eyes shall have reference tonometer intraocular pressures of 30 mmHg or higher. The time interval between each pair of repeated measurements shall be not less than 5 min.

B.5.4 The monitor shall ensure that a rule for stopping recruitment of test subjects has been specified and recorded in advance of the test, and that it is not conditional on the results obtained in the test.

NOTE To aid selection, the subjects can be invited to participate on the basis of prior knowledge of their respective pressures or by preliminary pressure readings.

B.5.5 One or both eyes of each subject shall be used. If the investigator chooses to measure only one eye, the choice shall be made before any pressures are taken with the test tonometer.

B.5.6 If, with any subject, it proves impossible to obtain all required readings with the reference tonometer or the test tonometer, the subject shall be withdrawn from the test. The investigators and the manufacturer shall report the number of subjects for whom measurements could not be made with each instrument and the reasons why.

B.6 Pressure readings

B.6.1 The order of testing with the reference and test instruments shall be specified and selected to minimize the effects of one measurement upon the next. The measurements with the test tonometer shall be as recommended by the manufacturer for routine use.

B.6.2 All specified readings on each eye shall be taken without interruption over as short a time period as possible; that is, the time interval between two successive measurements shall not be longer than approximately three times the time for one test run.

The test should be organized so that the subject has to move as little as possible.

B.7 Withdrawal from the test

B.7.1 The monitor shall ensure that the reasons for the withdrawal of any investigator, tonometer or subject are recorded.

B.7.2 If an investigator cannot complete the test, the monitor shall recruit a replacement. Measurements taken by the original investigator shall not be discarded.

B.7.3 The monitor shall ensure that no investigator's results can be influenced by the results of any prior reading.

B.7.4 The sponsor shall make provision for replacing any of the test tonometers that are accidentally damaged or which suffer a major fault that makes them unusable.

B.7.5 If the calibration of the reference tonometer is found to be incorrect, all readings taken subsequent to the last verification shall be discarded.

B.8 Recording the data and test termination

B.8.1 The monitor shall ensure that complete and accurate records are kept during the test.

B.8.2 The monitor shall design a data collection means for use in the test.

B.8.3 The monitor is responsible for terminating the test.

B.8.4 The monitor may terminate the test if it becomes obvious that the tolerances will not be met.

B.9 Data analysis

B.9.1 The monitor shall be responsible for the analysis of the test data.

B.9.2 When multiple measurements are made with the reference tonometer, the lowest measurement shall be used in the analysis. Where differences are greater than 5 mmHg, all measurements on this eye shall be excluded.

B.9.3 For each measurement pair, a difference shall be calculated by subtracting the reference tonometer measurement from the test tonometer measurement. This difference shall be compared with the tolerance found in Table 1 for that pressure range. The applicable pressure range shall be determined by the pressure measurement of the reference tonometer. If the difference is outside the tolerance range, that measurement pair shall be counted in the subset which falls outside the tolerance.

BSI - British Standards Institution

BSI is the independent national body responsible for preparing British Standards. It presents the UK view on standards in Europe and at the international level. It is incorporated by Royal Charter.

Revisions

British Standards are updated by amendment or revision. Users of British Standards should make sure that they possess the latest amendments or editions.

It is the constant aim of BSI to improve the quality of our products and services. We would be grateful if anyone finding an inaccuracy or ambiguity while using this British Standard would inform the Secretary of the technical committee responsible, the identity of which can be found on the inside front cover. Tel: +44 (0)20 8996 9000. Fax: +44 (0)20 8996 7400.

BSI offers members an individual updating service called PLUS which ensures that subscribers automatically receive the latest editions of standards.

Buying standards

Orders for all BSI, international and foreign standards publications should be addressed to Customer Services. Tel: +44 (0)20 8996 9001. Fax: +44 (0)20 8996 7001 Email: orders@bsigroup.com You may also buy directly using a debit/credit card from the BSI Shop on the Website <http://www.bsigroup.com/shop>

In response to orders for international standards, it is BSI policy to supply the BSI implementation of those that have been published as British Standards, unless otherwise requested.

Information on standards

BSI provides a wide range of information on national, European and international standards through its Library and its Technical Help to Exporters Service. Various BSI electronic information services are also available which give details on all its products and services. Contact Information Centre. Tel: +44 (0)20 8996 7111 Fax: +44 (0)20 8996 7048 Email: info@bsigroup.com

Subscribing members of BSI are kept up to date with standards developments and receive substantial discounts on the purchase price of standards. For details of these and other benefits contact Membership Administration. Tel: +44 (0)20 8996 7002 Fax: +44 (0)20 8996 7001 Email: membership@bsigroup.com

Information regarding online access to British Standards via British Standards Online can be found at <http://www.bsigroup.com/BSOL>

Further information about BSI is available on the BSI website at <http://www.bsigroup.com>.

Copyright

Copyright subsists in all BSI publications. BSI also holds the copyright, in the UK, of the publications of the international standardization bodies. Except as permitted under the Copyright, Designs and Patents Act 1988 no extract may be reproduced, stored in a retrieval system or transmitted in any form or by any means – electronic, photocopying, recording or otherwise – without prior written permission from BSI.

This does not preclude the free use, in the course of implementing the standard, of necessary details such as symbols, and size, type or grade designations. If these details are to be used for any other purpose than implementation then the prior written permission of BSI must be obtained.

Details and advice can be obtained from the Copyright and Licensing Manager. Tel: +44 (0)20 8996 7070 Email: copyright@bsigroup.com